

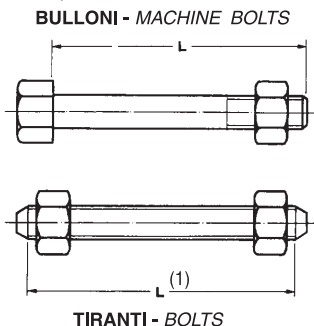

LUNGHEZZA DEI TIRANTI E BULLONI PER FLANGE

LENGTH OF STUD BOLTS AND MACHINE BOLTS OF FLANGES

CLASSE/CLASS
150/300/600



DIMENSIONS IN MM.	DN DEL TUBO NOMINAL PIPE SIZE	150					300					600				
		N°	Ø	TIRANTI STUD BOLTS L		BULLONI MAC. BOLTS RF	N°	Ø	TIRANTI STUD BOLTS L		BULLONI MAC. BOLTS RF	N°	Ø	TIRANTI / STUD BOLTS L		INCAMERAT. SEMPLICE E DOPPIA MALE & FEMALE
				RF	RJ				RF	RJ				RF	RJ	
1/2"	4	1/2	57		51	4	1/2	64	75	57	4	1/2	76	76	70	
3/4"	4	1/2	64		51	4	5/8	76	89	64	4	5/8	90	90	85	
1"	4	1/2	64	76	57	4	5/8	76	89	64	4	5/8	90	90	85	
1 1/4"	4	1/2	70	85	57	4	5/8	85	95	70	4	5/8	95	95	90	
1 1/2"	4	1/2	70	85	65	4	3/4	89	102	76	4	3/4	110	110	102	
2"	4	5/8	85	95	70	8	5/8	89	102	76	8	5/8	110	110	102	
2 1/2"	4	5/8	89	102	76	8	3/4	102	114	83	8	3/4	120	121	115	
3"	4	5/8	89	102	76	8	3/4	108	121	89	8	3/4	127	127	120	
3 1/2"	8	5/8	89	102	76	8	3/4	108	127	95	8	7/8	140	140	135	
4"	8	5/8	89	102	76	8	3/4	115	127	95	8	7/8	146	146	140	
5"	8	3/4	95	108	83	8	3/4	121	133	110	8	1	165	165	160	
6"	8	3/4	102	115	83	12	3/4	121	140	110	12	1	171	171	165	
8"	8	3/4	110	120	89	12	7/8	140	152	120	12	1 1/8	190	195	184	
10"	12	7/8	114	127	102	16	1	160	171	140	16	1 1/4	216	216	210	
12"	12	7/8	120	135	102	16	1 1/8	171	184	146	20	1 1/4	223	223	216	
14"	12	1	133	146	115	20	1 1/8	180	190	160	20	1 3/8	235	235	230	
16"	16	1	133	146	115	20	1 1/4	190	203	165	20	1 1/2	255	255	250	
18"	16	1 1/8	146	160	127	24	1 1/4	197	210	170	20	1 5/8	275	275	267	
20"	20	1 1/8	160	170	140	24	1 1/4	203	222	185	24	1 5/8	286	292	279	
24"	20	1 1/4	171	185	152	24	1 1/2	229	254	205	24	1 7/8	330	335	325	

1 - La lunghezza del tirante non include lo spessore della punta
Length of stud bolts does not include the height of the points

I bulloni sono previsti solo per la Classe 150 - 300
Machine bolts are foreseen for Class 150 - 300 only